



Hangar 6, Halfpenny Green Airport, Bobbington, Stourbridge, West Mids. DY7 5DY

Tel: +44 (0)1384 221600 or 07790 045959

[www.red-aviation.com](http://www.red-aviation.com)

email [malcolm@red-aviation.com](mailto:malcolm@red-aviation.com)

# **SERVICE BULLETIN**

**16<sup>th</sup> June 2016**

**Owner's Service Bulletin – OSB 29 Issue 1**

**Applicability – Ikarus C42 all models**

**Inspection of main fuselage tube for cracking around cut-outs**

**Classification:** Mandatory

## **Nature of Defect**

High hours examples of early C42 aircraft have exhibited cracks emanating from the corners of the cut-outs in the main fuselage tube where the nose-leg and A-strut are fitted.

See example photographs on following pages.

## **Airworthiness Implications**

If such cracks are allowed to propagate the structural integrity of the nose-leg, A-strut and engine mountings may be compromised.

## **Aircraft Affected**

All C42 aircraft.

The problem appears primarily to affect high hours (1000hr+) early examples of the C42 on which the affected cut-outs were made manually. Later models are machine cut, and are thought less likely to exhibit the problem but they remain subject to this service bulletin until further notice.

## **Hours of Operation**

In excess of 1000 hours.



Red Aviation

Hangar 6, Halfpenny Green Airport, Bobbington, Stourbridge, West Mids. DY7 5DY

Tel: +44 (0)1384 221600 or 07790 045959

[www.red-aviation.com](http://www.red-aviation.com)

email [malcolm@red-aviation.com](mailto:malcolm@red-aviation.com)



## Location and Examples

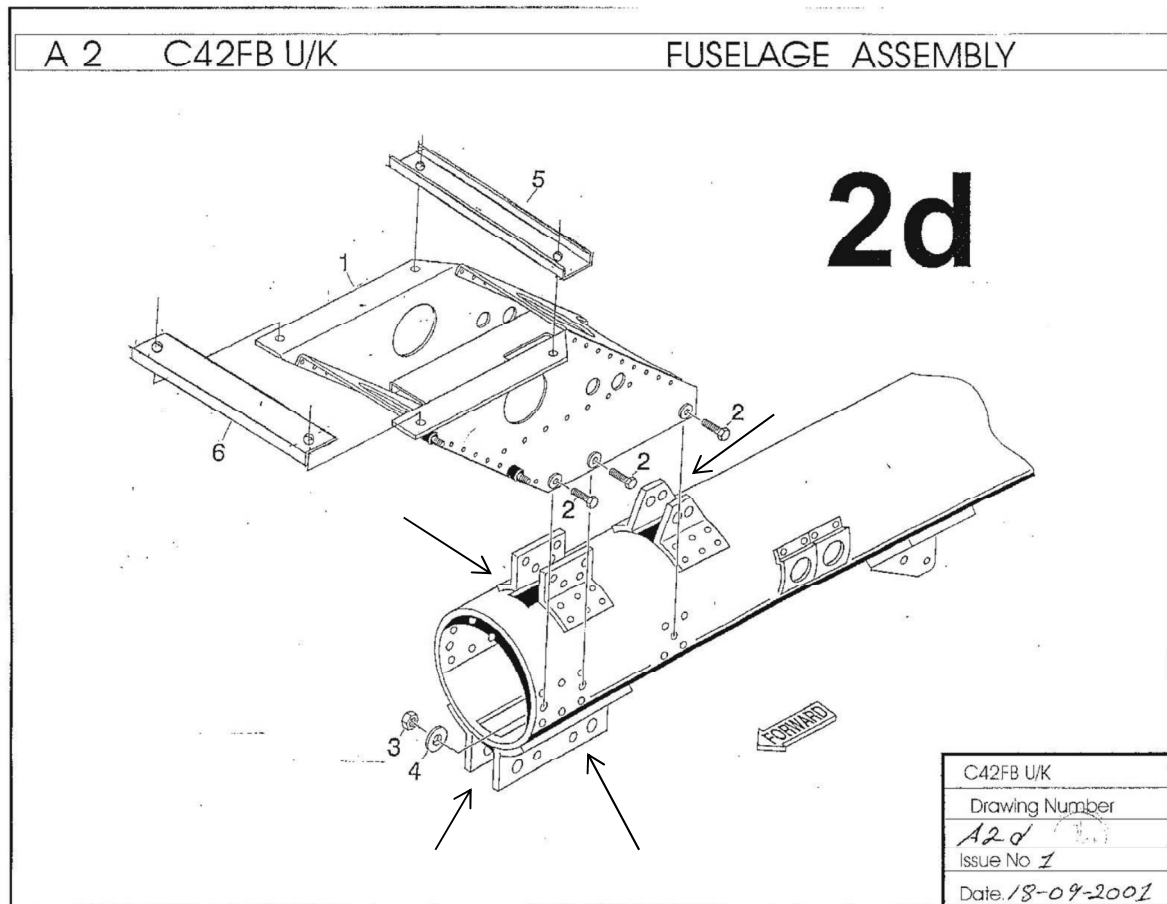

Nose-leg and A-strut cut-outs at front of main fuselage tube in vicinity of engine mount.

- Notes: 1. the stainless steel brackets securing the A-strut to the top side of the fuselage tube (the rearmost brackets shown above) were lengthened compared to those shown in the diagram above in around 2007, see the photo further below.
2. the holes for the A-strut attachment (the rearmost set of holes, one in the top of the main fuselage tube, one in the bottom) were eliminated entirely around 2015.



Red Aviation

Hangar 6, Halfpenny Green Airport, Bobbington, Stourbridge, West Mids. DY7 5DY

Tel: +44 (0)1384 221600 or 07790 045959

[www.red-aviation.com](http://www.red-aviation.com)

email [malcolm@red-aviation.com](mailto:malcolm@red-aviation.com)

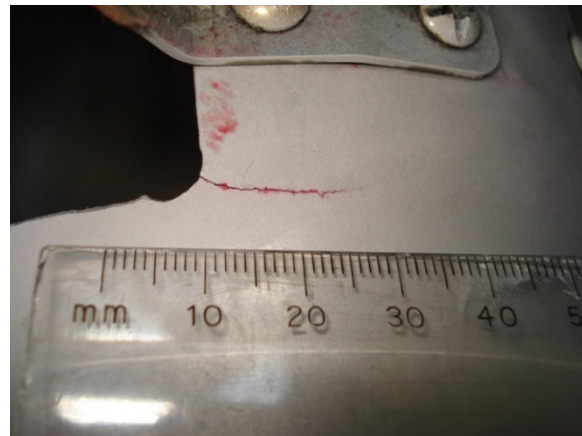
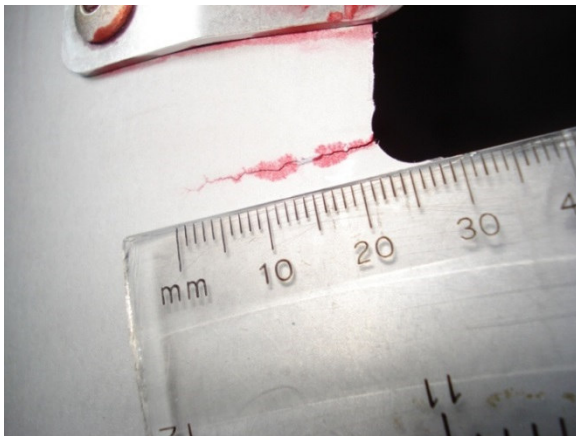
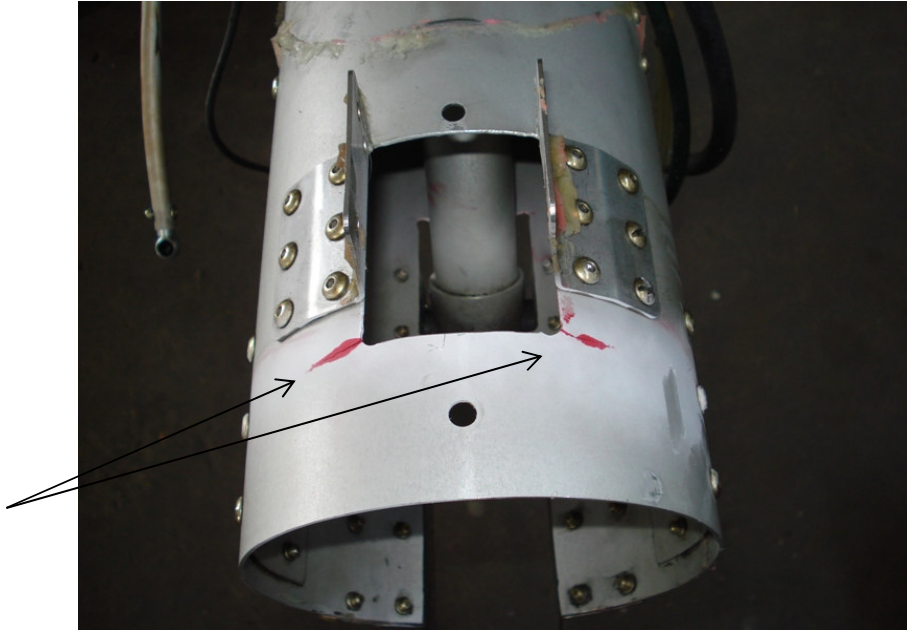

Example cracks on upper surface of main fuselage tube at corners around nose-leg cut-out.



Red Aviation

Hangar 6, Halfpenny Green Airport, Bobbington, Stourbridge, West Mids. DY7 5DY

Tel: +44 (0)1384 221600 or 07790 045959

[www.red-aviation.com](http://www.red-aviation.com)

email [malcolm@red-aviation.com](mailto:malcolm@red-aviation.com)

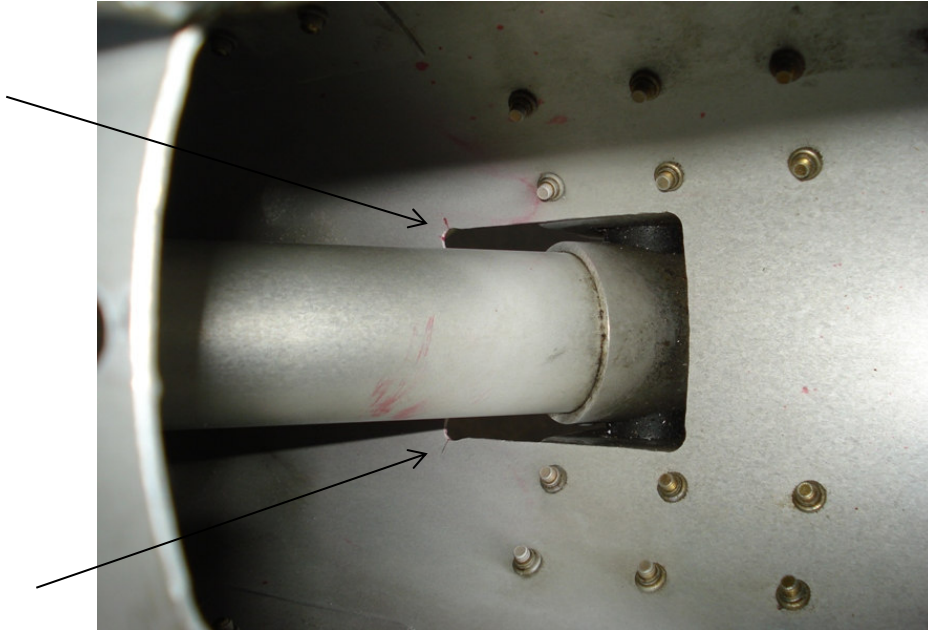

Example cracks on lower surface of main fuselage tube at corners around A-strut cut-out.





Red Aviation

Hangar 6, Halfpenny Green Airport, Bobbington, Stourbridge, West Mids. DY7 5DY

Tel: +44 (0)1384 221600 or 07790 045959

[www.red-aviation.com](http://www.red-aviation.com)

email [malcolm@red-aviation.com](mailto:malcolm@red-aviation.com)



Example of significant crack allowed to propagate on 4500hr aircraft. This crack was hidden by the firewall sound-deadening foam. Ensure that it is removed for inspection.

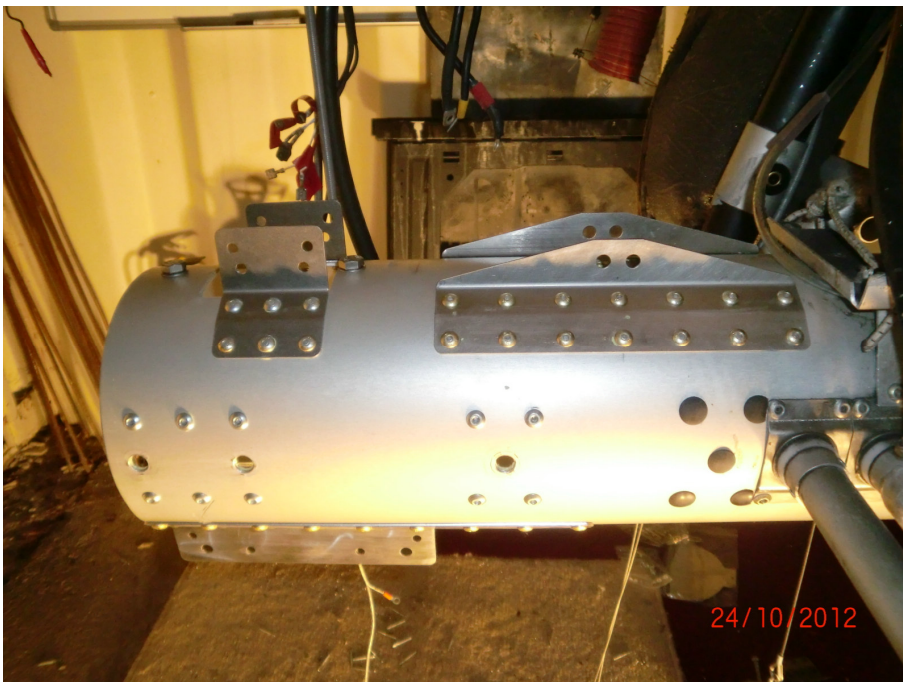

Lengthened A-strut top attachment brackets as found on aircraft from around 2007.



Hangar 6, Halfpenny Green Airport, Bobbington, Stourbridge, West Mids. DY7 5DY

Tel: +44 (0)1384 221600 or 07790 045959

[www.red-aviation.com](http://www.red-aviation.com)

email [malcolm@red-aviation.com](mailto:malcolm@red-aviation.com)

## **Rectification Action Required**

### **(a) Inspection**

The following references to aircraft hours assumes the original fuselage tube is still fitted. If this has been replaced then the operating hours may be taken to refer to those since the replacement.

(i) For aircraft with over 2000 hours of operation, BEFORE NEXT FLIGHT either perform the inspection (ii) below or perform the following inspection:

Remove the area of sound-deadening foam on the cockpit side of the firewall which hinders inspection of the A-strut cut-out just forward of the rudder pedals on the top of the main fuselage tube. This is the area which concealed the significant crack shown in the example photographs above.

Remove the upper and lower engine cowlings.

As thoroughly as possible, subject to the restricted access, inspect the main fuselage tube in the vicinity of the nose-leg and A-strut attachment cut-out areas for the development of significant cracks such as the one shown in the example photographs above.

The owner may perform this inspection.

Record the inspection and the results in the aircraft airframe logbook.

(ii) For aircraft with over 1000 hours of recorded operation perform the following inspection at the next annual or 100 hour inspection whichever occurs first and at 500 operating hour intervals thereafter:

The perimeter of the cut-outs in the main fuselage tube where the nose-leg and A-strut pass through the main fuselage tube must be visually inspected for cracking, with particular attention paid to the corners.

Both top and bottom cut-outs must be inspected, 4 cut-outs in total (except on very recent aircraft which have no cut-outs for the A-tube).

This may be carried out directly or by boroscope. For direct inspection the engine cowlings, lower fuselage fairing and parts of the firewall sound-deadening foam must be removed, consult the builders manual for detailed instructions.



Red Aviation



Hangar 6, Halfpenny Green Airport, Bobbington, Stourbridge, West Mids. DY7 5DY

Tel: +44 (0)1384 221600 or 07790 045959

[www.red-aviation.com](http://www.red-aviation.com)

email [malcolm@red-aviation.com](mailto:malcolm@red-aviation.com)

In case of doubt, a visual inspection with the aid of dye-penetrant crack detection is recommended.

The owner may perform this inspection, but if not experienced in such inspection and especially if using dye-penetrant, the assistance of a suitably experienced BMAA or LAA Inspector is recommended.

Record the inspection and the results in the aircraft airframe logbook.

**(b) Repair**

If any cracking is found please contact Red Aviation. An approved repair scheme involving the fitment of an inner sleeve to the forward end of the main fuselage tube is available.

**(c) POH Amendment**

The Pilot's Operating Handbook (POH) should be annotated on the "Inspection and Maintenance, 100hr or Annual Inspection" page to record the requirement for the above inspection. Future issues of the POH will incorporate this amendment.

**Approved by:**

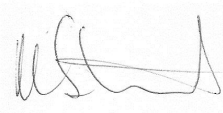
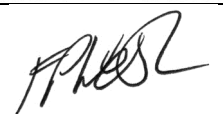
Position	Signature	Date
Technical Manager		16/06/2016
Engineering Design Consultant		16/06/2016